

PRODUCTION SPECIFICATION

PORTRAIT SIDE

THINK
BIG.

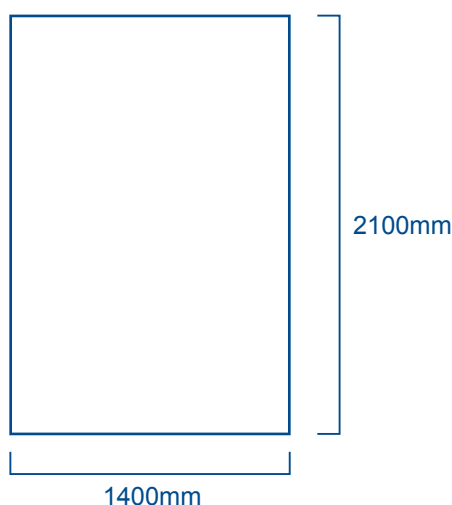

Artwork	Visual & Finished size: 466.66mm (w) x 700mm (h) (1/3 scaling) plus 4mm bleed all sides (no trims)
Actual	Visual and Finished size : 1400mm (w) x 2100mm (h)
Accepted Format	High resolution Print Ready PDF files (maximum PDF file size of 500MB) Preferred option is for layered file to be exported with PDF/X-4 setting
Resolution	All high resolution images and files are to be supplied 300dpi at artwork size (CMYK)
Black Specification	All blacks to be supplied as CMY = 60% and K = 100% (disable overprint)
Fonts	All fonts / text to be converted to outlines
Barcodes	A unique barcode ID will be provided for artwork approved for display by BBA The scannable barcode MUST be printed in the bottom left corner of the visible area
File Transfer	Hi-Res PDF via Wetransfer.com Supplied files to be labelled with 'Campaign ID_DesignName'

BBA Approved Substrates and Production Method

SAV	AVERY MPI 3111, DECOBUS RITRAMA with HYBRID II or PE LINER, MACTAC MACal 8129HGR (Screen printing) or MACTAC MACJT5829RM (Digital printing)
Perforated Window Film	Contravision WBPRG40 (replacement liner only) or Clear Focus Classic Vue CFEABW (solid paper release liner only)
Production Method	Perforated window film top section & SAV bottom section Top and bottom sections require 250mm overlap across join ie: 1400mm (w) x 1300mm (h)
Spares	10% spares are to be supplied in addition to the booked media quantity
Labelling	All material delivered to BBA installers MUST be labelled clearly and contain the following: 1. Campaign Name, 2. Panel size, 3. Qty (inc.spares), 4. Barcode image & number
Deadlines	Finished Artwork is required 21 days prior to the campaign start date Finished Material is required 7 days prior to the campaign start date